

CODE	DESCRIPTION
110477	LIMIT SWITCH FOR TABLE 90Ø
260126	SCREW TE 5X12
260224	TB-SCREW 6X15 B23-10-11-12
260416	STAINLESS STEEL NUTS M6
260426	DADI ESAG.CIECHI INOX "M6"
260512	ST/ST GROWER WASHER D6
260530	STAINL.ST WASHER 7X22X2
320639	PLATE
331394	WASH HOSE
331979	BRACKET
332365	SQUADRETTA GUIDAC.SCAR.90Ø S-D
332366	SQUADRETTA GUIDAC.SCAR.90Ø D-S
341149	TELAIO X MENS.RIB.SCAR.CES.90Ø
342046	COVER FOR SWITCH
342824	TABLE
342825	MENSOLA RIBAS.D-S XSC.CEST.90Ø
351394	PANN.LATERALE SCARIC. CEST.90Ø
351407	PANEL
351417	PANNELLO LATO RULLIERA SCA.90Ø
440201	RUBBER FOOT D.60X10

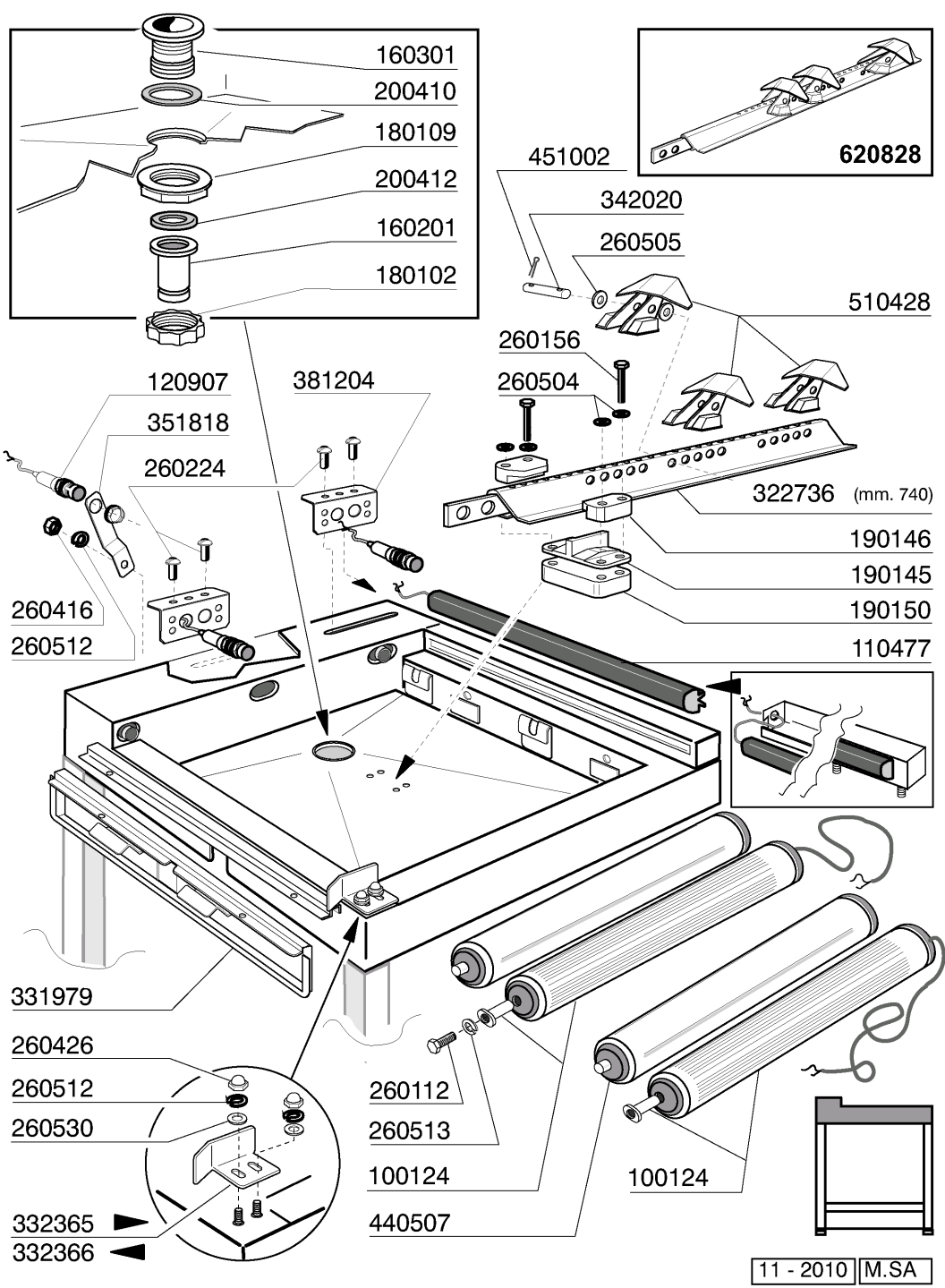

3 - Tank

CODE	DESCRIPTION
100124	ROLLER WITH MOTOR
110477	LIMIT SWITCH FOR TABLE 90Ø
120907	PHOTOCELL F. TRAY WASHER E3FDS-
160201	ELBOW F. TANK INLET MOPLN
160301	DRAIN OUTLET 1"1/2 C-S-N
180102	DRAIN PIPE NUT 1"1/2 F45-55
180109	LOCK NUT 1 1/2"
190145	SUPPORT F. PAWL BAR GUIDE AC
190146	CLAMPING PIECES AC
190150	BLOCCHETTO X SUPPORTO GUIDA
200410	DRAIN OUTL. WASH. 1 1/2"65X47X2
200412	GASKET DRAIN 1 1/2" 45X33X3
260112	STAINLESS STEEL TE-SCREW 8X16
260156	VITE T.E. M6X60 INOX A2 5739
260224	TB-SCREW 6X15 B23-10-11-12
260416	STAINLESS STEEL NUTS M6
260426	DADI ESAG. CIECHI INOX "M6"
260504	ST/ST FLAT WASHER D6
260505	STAINL. STEEL FLAT WASHER D8
260512	ST/ST GROWER WASHER D6
260513	GROWER WASHER D8
260530	STAINL. ST WASHER 7X22X2
322736	GUIDA L=704 PORTAS. SCARIC. 90Ø
331979	BRACKET
332365	SQUADRETTA GUIDAC. SCAR. 90Ø S-D
332366	SQUADRETTA GUIDAC. SCAR. 90Ø D-S
342020	PIN
351818	BRACKET
381204	PHOTOCELL SUPPORT
440507	ROLLER 50X550 STAINL. ST 1100/7
451002	COTTER PIN STAINL. ST. D2X12
510428	PAWL LOAD.
620828	TRAINO CON 3 SALT. X SCAR. 90Ø

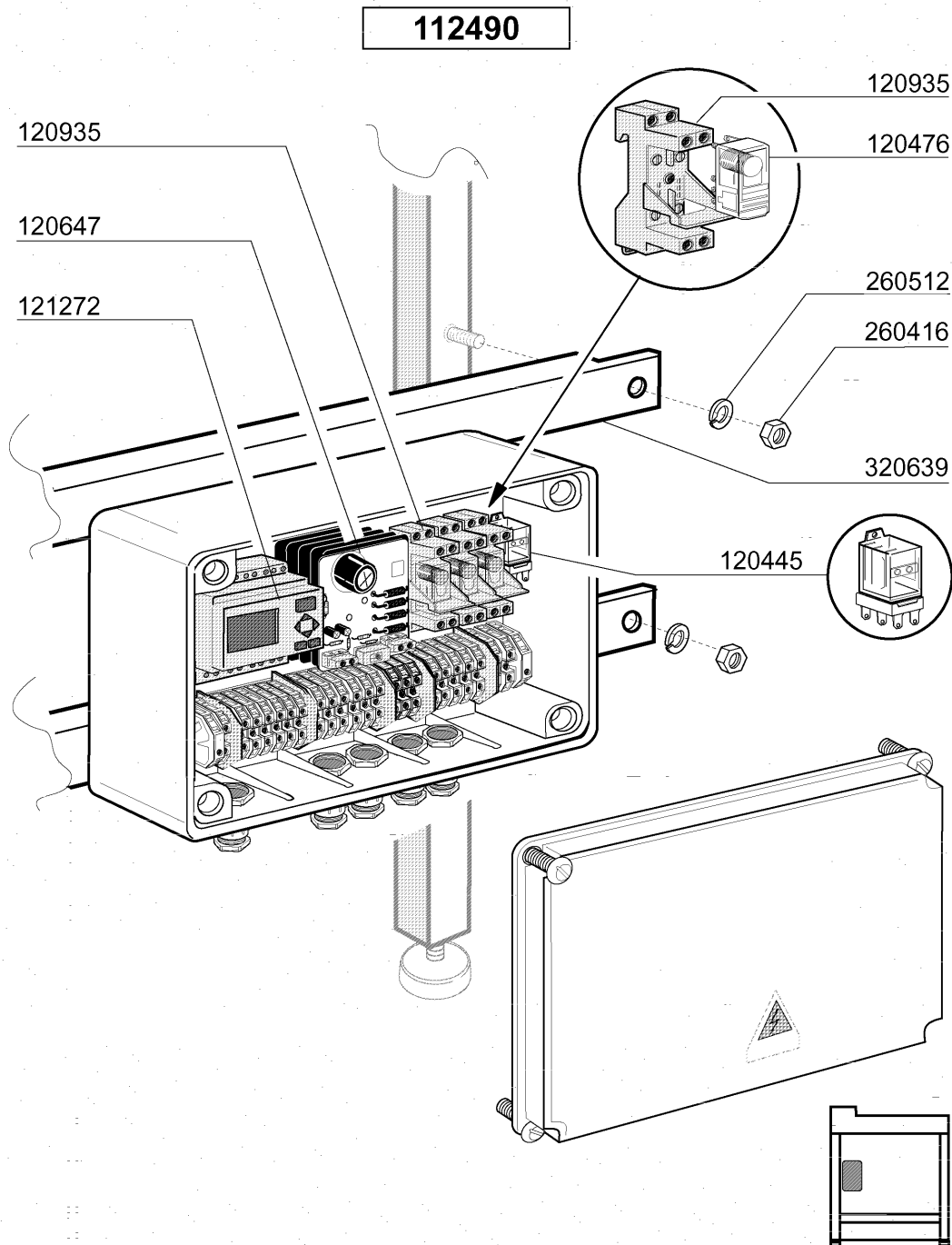

03 - 2005 | S. AG.

4 - Control box

CODE	DESCRIPTION
112490	CABLE
120445	AUXILIARY RELAY S.B2/3 24V
120476	RELAY 16A 24V
120647	TRANSFORMER 24V-2A
120935	SUPPORT
121272	PLC
260416	STAINLESS STEEL NUTS M6
260512	ST/ST GROWER WASHER D6
320639	PLATE